



LOVED IN 70 COUNTRIES

**YOUR FAVOURITE  
BOXER 100CC**  
NOW AVAILABLE WITH ALLOY WHEELS

# Owner's Manual



-  FUEL EFFICIENCY
-  DURABILITY
-  POWER
-  COMFORT
-  LOW MAINTENANCE

**BOXER**  
MADE STRONGER TO LAST LONGER

## Identification Data

**BOXER** BM 100

### Description

1. Technical Specifications..... 1	7. Periodic Maintenance Information..... 13
2. Location of Parts..... 2	8. Periodic Maintenance & Lubrication..... 15
3. How to Ride Motorcycle..... 9	9. Periodic Part Replacement Schedule..... 17
4. Safe Riding Tips..... 10	10. Pre Delivery Inspection..... 18
5. Daily Safety Checks..... 11	11. Applicable to Periodic Services..... 19
6. Running In Instruction..... 12	12. Non-use Maintenance..... 20

### Safety and Warning information :

**Warning :** This indicates that a potential hazard or injury to you or other persons & to the vehicle can happen if advice provided is not followed

**Caution :** This indicates that a potential hazard that could result in vehicle damage. Follow the Advice provided with the caution.

**Notice:** The description and illustration in this booklet are not to be taken as binding on the manufacturers. The essential features of the type described and illustrated herein remaining unaltered. Bajaj Auto Limited reserves the right to carry out at any moment without being obliged to bring this booklet upto-date. Modifications on the vehicle, parts or accessories as may be convenient and necessary.

## Technical Specifications

**BOXER** BM 100

<b>Engine</b>	: 4 stroke, Single cyl. Air cooled, SI Engine.	<b>Dimensions :</b>	
Bore x Stroke	: 53.0 mm x 45.0 mm	Length	: 1970 mm
Engine Displacement	: 99.27 cc	Width	: 770 mm
Compression Ratio	: 9.5 : 1	Height	: 1065 mm
Idling Speed	: 1300 ± 100 rpm	Wheel base	: 1235 mm
Max. Net Power	: 6.03kW (8.2Ps) at 7500 rpm	Min. Turning radius	: 1900 mm
Max. Net Torque	: 8.05 Nm at 4500 rpm	Ground clearance	: 150 mm (Min.)
Ignition System	: Digital CDI with twin map ignition	Electrical System	: 12 Volts AC + DC
Spark Plug	: Mico UR3AC, Champion PRZ9HC	Head Lamp	: 35/35 W
Spark Plug Gap	: 0.6 to 0.7 mm	Position Pilot Lamp	: 3W
<b>Lubrication</b>	: Wet sump, Forced.	Stop Lamp/Tail Lamp	: 21 W / 5 W
Transmission	: 4 speed constant mesh.	Turn Signal Lamp	: 10 W
<b>Brake Front / Rear</b>	: Mech. expanding shoe.	Neutral Indicator Lamp	: 3 W
<b>Fuel Tank Capacity :</b>		Hi Beam Indicator Lamp	: 3 W
Full	: 9.3 litres	Turn Pilot Indicator Lamp	: 3 W
Reserve	: 2.2 litres	Speedometer Lamp	: 3 W (2 Nos.)
Usable Reserve	: 1.2 litres	Horn	: 12 V DC
<b>Tyre Size</b>	:	Battery	: 12 V-2.5 Ah
Front	: 2.75 x 17	Vehicle Kerb Weight	: 109 kg.
Rear	: 3.00 x 17	Gross Vehicle Weight	: 239 kg.
<b>Tyre Pressure :</b>		Max. Speed	: 90 km/hr. (single rider 68 kg)
Front	: 1.75kg / cm <sup>2</sup> (24.5 PSI)	Climbing ability	: 25% (14°) max.
Rear (solo)	: 2 kg / cm <sup>2</sup> (28 PSI)		
Rear (pillion)	: 2.50 kg / cm <sup>2</sup> (36 PSI)		

**Note :** All dimensions are under UNLADEN condition. Above information is subject to change.

## Location of Parts

**BOXER** BM 100

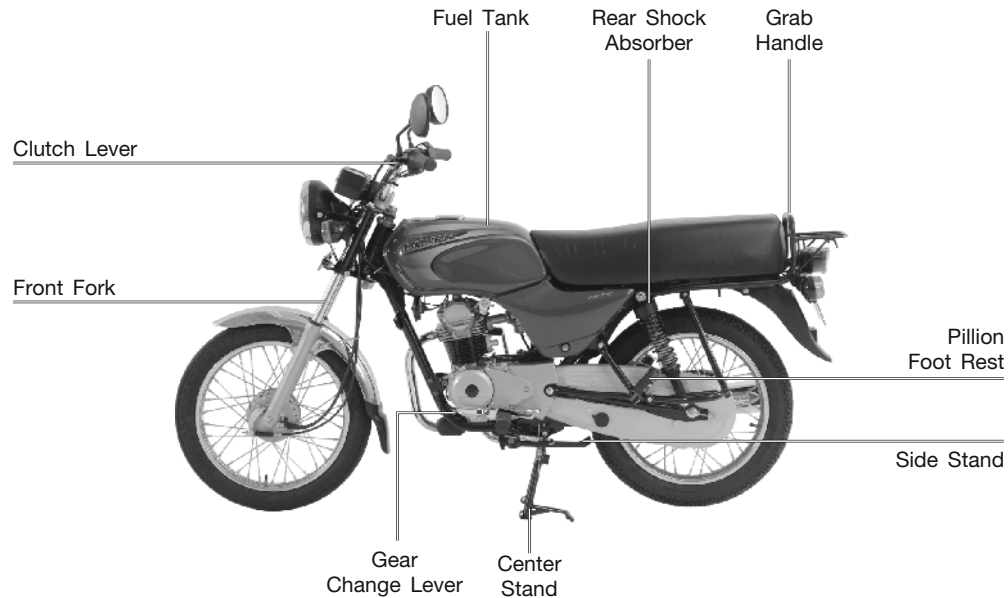

## Location of Parts

**BOXER** BM 100

The Frame and Engine serial numbers are used to register the motorcycle. They are the unique alpha-numeric codes to identify your particular vehicle from others of the same model and type.

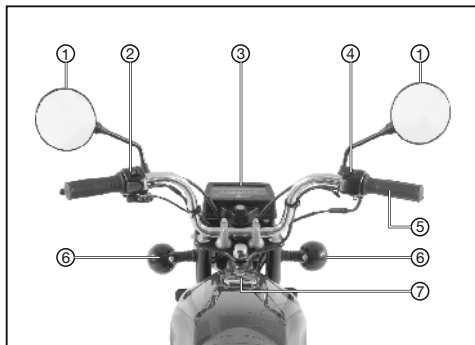
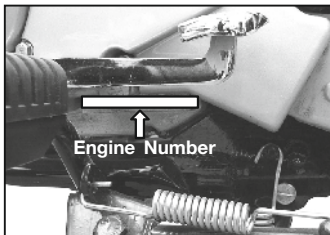

1. Mirror - LH/RH
2. Control Switch LH
3. Speedo Console
4. Control Switch RH
5. Throttle Grip
6. Indicators LH/RH
7. Fuel Tank Cap

## Location of Parts

**BOXER** BM 100

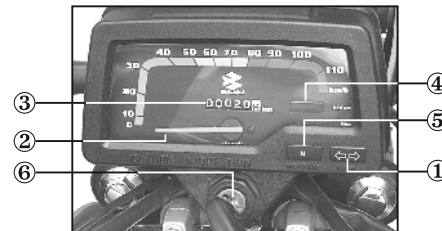

1. **Turn Signal Indicator (LH & RH)** : When turn signal switch is turned to Left or Right, Turn pilot indicator will flash with engine running.
2. **Speedometer** : The Speedometer pointer shows the speed of vehicle.
3. **Odometer** : The Odometer shows the total distance that the vehicle has accumulated.
4. **Hi beam Indicator** : When Headlight is 'ON' and Hi beam is selected with engine running, Hi beam indicator will be lit.

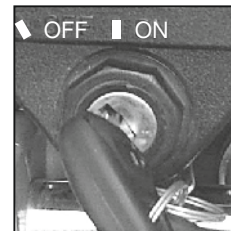

5. **Neutral Indicator** :  
When the transmission is in Neutral and Ignition switch 'ON', with engine running the Neutral indicator is lit.
6. **Ignition Switch** : Key operated switch for Ignition 'ON'/'OFF'.

### Ignition ON & OFF :

- |     |                 |
|-----|-----------------|
| OFF | : Ignition OFF. |
| ON  | : Ignition ON.  |

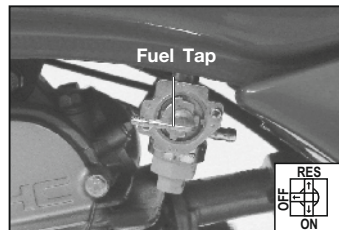
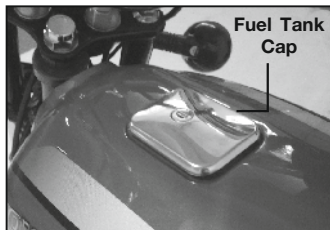
**Steering Lock ON & OFF :**

**To Lock the Steering :** To lock the steering, turn the handle bar to the left. Turn the key to “LOCK” position and remove the key.

**To Lock the Steering :** To lock the steering, insert the key in steering lock & turn it anticlockwise to “ON”.

**To Unlock the Steering :** To unlock the steering, insert the key in steering lock & turn it clockwise to “OFF”.

**Key :** A common key is used for Steering lock, Ignition lock, Fuel tank cap and Side cover lock.

**Fuel Tank Cap**

- To open the fuel tank cap, insert the key in the lock and turn it clockwise and lift fuel tank cap.
- ‘Fuel Tank Cap’ is locked when pushed back into the place.

**Fuel Tap**

Fuel tap lever has following positions.

- ON :** When fuel level is above Reserve position.
- RES :** When fuel level is below Reserve position.
- OFF :** When fuel supply is to be cut off.

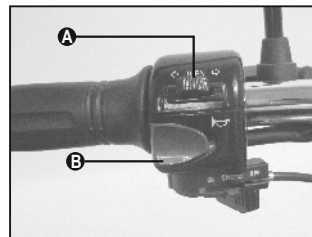

**Left Handle Bar Switches****A. Turn Signal Switch :**

- ↶ : When the turn signal switch is turned to Left the Left side Front and Rear turn signal flash ‘ON’ and ‘OFF’.
- ↷ : When the turn signal switch is turned to Right the Right side Front and Rear turn signal flash ‘ON’ and ‘OFF’.

**B. Horn Button :**

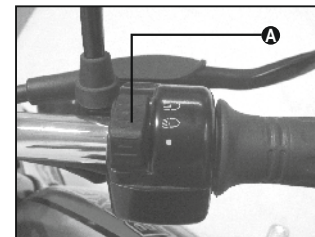
-  : Press horn button for sounding horn.

**Right Handle Bar Switches****A. Head Light Switch :** It has 3 positions.

- : All lamps ‘OFF’.
-  : With engine running, Low beam, Tail lamp and Meter lamps ‘ON’.
-  : With engine running, High beam, Tail lamp and Meter lamps ‘ON’.

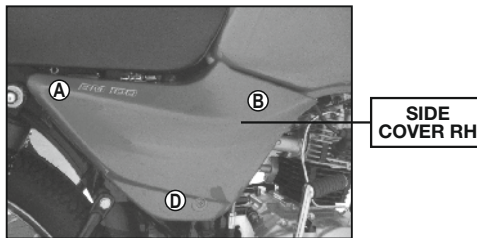
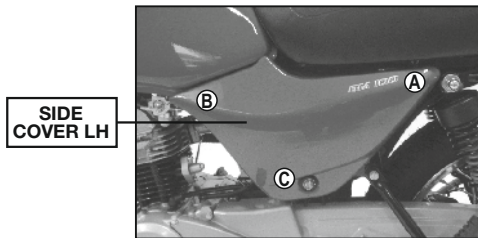
**Removal Of Side Cover LH and RH**

- Insert the key into cover lock (C) & turn the key clockwise & pull 'Side cover' LH out from bottom.
- Pull 'Side cover' from (A) to release Lug provided on 'Side cover' from hole provided on 'Frame'.
- Slide the 'Side Cover' forward (towards the engine) from location (B) to release slot provided on front side of 'Side cover' from bracket with rubber cap provided on 'Fuel Tank'. Take out 'Side cover'.
- Similarly 'Side cover' RH can be removed after removing screw (D).

**Caution :** Remove cover as described above, otherwise the lugs may break.

**Fitment Of Side Cover LH and RH**

- Match slot (B) provided on front side of 'Side Cover' with bracket provided on 'Fuel Tank' and slide 'Side cover' backward (towards Tail lamp).
- Match Lug (A) provided on rear side of 'Side cover' with hole provided on 'Frame' and press 'Side cover' inside.
- Match the lock plate of 'Side cover' properly with bracket on 'Chassis' and Lock. (For 'Side cover' LH).
- For 'Side cover' RH adopt same procedure and fit the screw (D) properly.

**Caution :** Fit cover as described above to ensure proper fitment.

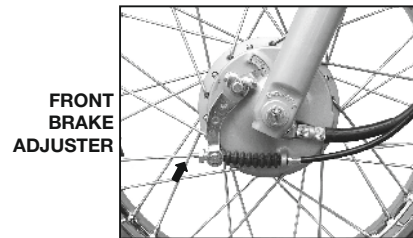
**Front Brake Adjustment**

For safe riding, the brakes must always be maintained in perfect condition. Brake is properly adjusted if

- The wheel rotates freely when the control lever is in the resting position.
- The braking action starts after Front brake lever is pressed by 2-3 mm.

These conditions are obtained by adjusting the cables by means of adjuster shown in the figure and minor play adjustments can be done by adjuster provided near front brake lever.

**Rear Brake Adjustment**

Rear brake is properly adjusted if

- The wheel rotates freely when the brake pedal is in the resting position.
- The braking action starts after Brake pedal is pressed by 20-30 mm.

These conditions are obtained by adjusting the cables by means of adjuster shown in the figure.

**Warning :**

**Brakes are items of personal safety and hence must be maintained in perfect condition.**

### Starting the engine :

- Keep the fuel tap to **ON** or **RES** position.
- Turn ignition switch to **ON** position.
- Confirm that the vehicle (transmission) is in neutral.
- If the engine is cold or when starting for first time, use choke for quick starting. Choke lever **(A)** is located on LH side switch.
- Keep the **throttle completely closed**, and kick the engine with kick starter lever.
- When the engine is warmed up enough to idle without using choke, return the choke to OFF position.

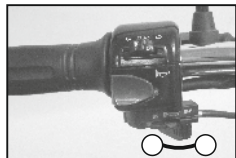

**A : Choke "ON"**  
**B : Choke "OFF"**

**Note :** When the engine is already warm on hot days (Higher than 35°C), open the throttle part away instead of using the choke, and then start the engine. It is recommended to start the engine with the transmission in neutral.

### Moving off :

- Check that Center/Side stand is up.
- Depress the clutch lever.
- Shift into 1<sup>st</sup> gear.
- Open the throttle and release the clutch lever slowly and simultaneously.
- As the clutch starts to engage, open the throttle a little more, giving the engine just enough fuel to keep running.

### Shifting gears :

- Close throttle & depress the clutch.
- Shift into next higher or lower gear.
- Open the throttle and release the clutch lever slowly and simultaneously.

**Warning :** When shifting down to lower gear, do not shift at such a high speed that the engine rpm rises excessively and which may cause the rear wheel to skid.

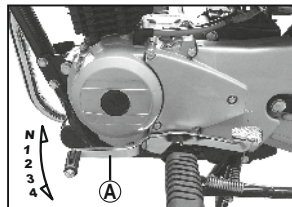

**A : Gear Shifting Lever**

### Braking :

- Close the throttle completely, leaving the clutch engaged (except while shifting gears) so that the engine braking will help slow down the motorcycle.
- Shift down one gear at a time so that you are in Neutral when you come to a complete stop.
- When stopping, always apply both brakes at the same time. Normally the front brake should be applied a little more than the rear. De-clutch as necessary to keep the engine from stalling.
- Never lock the brakes, or it will cause the tyre to skid. When cornering, use brakes judiciously and do not de-clutch. Reduce your speed before you get into the corner.
- For emergency braking, disregard downshifting, and concentrate on applying the brakes as hard as possible without skidding.

### Stopping the vehicle :

- Close the throttle completely.
- Shift the transmission into neutral.
- Bring the vehicle to complete stop.

- Turn the ignition switch off.
- Support the motorcycle on a firm level surface with the center or side stand & lock the steering.

### Parking :

- Shift the transmission into neutral and turn the ignition switch OFF.
- Support the motorcycle on a firm level surface with the center or side stand.

**Caution : Do not park on a soft or steeply inclined surface other wise the motorcycle may fall over.**

### Safe Riding Tips

- **Wear A Helmet :** Always wear a helmet while riding. Your helmet should conform as per your country standards.
- Read thoroughly the instructions in this manual and follow them carefully.
- Avoid unnecessary accessories for the safety of both rider and other motorists.
- Get familiar with traffic rules & regulations in your states as well as general traffic signs.
- Do not overload your vehicle.

- Familiarise yourself well with starting, acceleration and braking of the vehicle.
- When applying the brakes, use both, the front and rear brakes. Applying only one brake may cause the rider to lose control, use more of the front than rear judiciously depending on road surface conditions.
- Riding at proper speed and avoiding unnecessary acceleration and braking are important not only for safety and low fuel consumption, but also for longer life of the vehicle and smooth operation.
- During rainy season ride the vehicle more cautiously. Remember vehicles skid more easily during light showers.
- Drive cautiously. Start early and reach your destination safely.
- Always carry vehicle registration papers, insurance and a valid driving licence with you.
- **Rainy Season Care : Fit & Finish Parts**  
It is suggested to customer to take appropriate care in area of heavy monsoon or high rainfall area.

The appropriate surface preventive coat to avoid rusting / poor surface finish on account of adverse atmospheric conditions.

- Enough **fuel level** for planned distance of journey. No fuel leakage in fuel lines.
- **Engine oil** level (bet<sup>n</sup> upper - lower level mark)
- **Throttle cable** play of 2 - 3 mm. Smooth operation & positive return to closed position,
- **Steering Lock** lever not fouling.
- **Brake Pedal** Play - 20 to 30 mm.
- **Wear lining Indicator** within usable range. no brake dragging.
- **Drive Chain** slack of 25 to 35 mm adequately lubricated.
- Function of all **lights & horn**
- Smooth **steering movement** without restriction
- **Clutch lever** play - 2 to 3 mm
- **Both stands** return to their fully up position.
- Correct **inflation pressure** in both tyres adequate tread depth - no cracks / cuts.
- Correct **rear viewing** span adjustment of mirror.

Proper running-in is important for the better life and trouble free performance of the vehicle.

- During first 2000 kms running-in period do not exceed following speed limits.

Kms	1st	2nd	3rd	4th
0 - 1000	15	30	45	55
1000 - 2000	20	40	60	75

- Always keep the speed below the limits mentioned in the table.
- Do not race the engine excessively.
- Do not start moving or race the engine immediately after starting. Run the engine for a minute at idle speed to give the oil a chance to workup into the engine.
- Do not run at constant speed. Vary the engine speed.

### Fuel Saving Tips :

A well maintained vehicle and good driving can contribute a lot to the saving of petrol. Following are a few simple fuel saving tips.

### Good Riding Habits :

- Ride smoothly and steadily at an optimum driving speed of 40 to 45 Km/h.
- Avoid harsh braking.

- Change the gear judiciously according to the speed & load requirement.
- Don't overload the vehicle above the specified payload.
- Use the accelerator judiciously.
- Cut off the engine if you want to stop for more than two minutes.

### Vehicle Maintenance (Ensure Following)

Fuel	Check fuel lines and connections for leakage.
Spark plug	Inspect and clean spark plug. Adjust electrode gap. Replace periodically
Air filter	Clean / Replace the air filter element periodically.
Engine oil	Check level. Use recommended grade and quantity.
Brakes	Ensure that the brakes are not dragging / binding.
Clutch	Ensure correct clutch lever play.
Tyre pressure	Always maintain the recommended tyre pressure.
Carburettor	Clean and adjust the carburettor. Adjust idling speed.



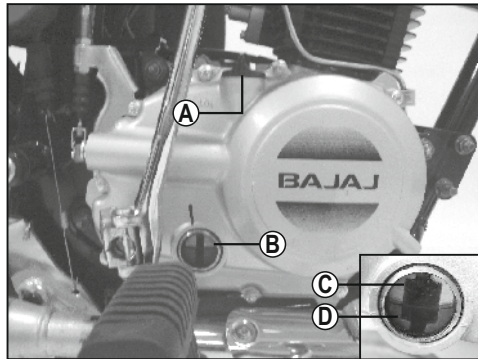

**A : Oil filler cap**

**B : Oil level gauge**

**C : Upper level**

**D : Lower level**

**Engine Oil : Check every week**

- Always maintain engine oil level between the upper and lower mark provided on oil window.
- Replace the oil in accordance with periodic maintenance chart.

**Engine Oil Level Checking :**

- Park the vehicle on level surface at center stand to check the oil level.
- Check the oil level through the oil inspection gauge as shown in the figure.a

Recommended Oil	SAE 20W40 of API 'SJ'+JASO 'MA' or SAE 20W40 of API 'SL'+JASO 'MA' grade
Oil Capacity	900 ml.

It is most vital to adhere to recommended frequency of oil change for the purpose of long life of critical engine components. For details refer periodic maintenance chart.

**Oil Strainer**

- Oil strainer is situated inside clutch cover.
- Oil Strainer should be cleaned periodically at Vehicle Dealer / Authorised Service Center.



**Wheel Puncture**

Use the recommended levers while removing the Tyre / Tube for puncture work. This will avoid any damages to the edges / scratches on paint of the wheel.



**Tool Kit Location**

- It is located inside the 'Side Cover' LH.
- A rubber strap is provided to hold the tool kit.
- It can be used to keep First Aid Kit.

**Spark Plug**

- Remove spark plugs by using plug spanner.
- Clean the spark plug.
- Adjust the gaps if incorrect by bending outer electrode carefully.

**Spark plug gap** : 0.6 to 0.7 mm.

**Spark Plug** : Mico UR 3 AC or Champion PRZ 9 HC

**Tyre Pressure**

Keep appropriate tyre pressure as mentioned below to increase life of the tyre & for better fuel consumption.

Front	1.75 kg/cm <sup>2</sup> (24.5 psi)
Rear (Solo)	2.00 kg/cm <sup>2</sup> (28 psi)
Rear (Pillion)	2.50 kg/cm <sup>2</sup> (36 psi)

**Battery (12V - 2.5 Ah)**

- Battery is located inside 'Side cover' LH.
- Check the electrolyte level in each cell and ensure that it is between the upper and lower level lines.
- Remove the battery filler caps and fill with distilled water until the electrolyte level in each cell reaches the upper level line.
- Add only distilled water to the battery. Tap water is not a substitute for distilled water and will shorten the life of the battery.
- Environment care is to be taken to dispose off the used battery. It is always recommended to hand over the same to the Authorised battery / Bajaj dealer for proper disposal of the same.

## Periodic Maintenance & Lubrication Chart

**BOXER** *EM 100*

Sr. No.	Operation	Which ever comes first ↓		RECOMMENDED FREQUENCY			
				Initial		Subsequent	
		OR	Kms.	500-750	2,500 kms.		Every 2,500km
	Days	30 - 45	240 days from date of sale		Every 75 days		
1.	Servicing		P	P	P	P	
2.	Carburetor / Idle speed / CO %		CL,A	CL,A	CL,A	CL,A	
3.	Engine oil		R		R		Every 5000 kms
4.	Valve tappet clearance		C,A		C,A		Every 5000 kms
5.	Oil strainer / Centrifugal filter		CL				Every 10000 kms
6.	Air cleaner element		CL	CL	CL	CL	R - Every 10000 kms
7.	Fuel system leakage		C	C	C	C	C, R - if required
8.	Air breather tube		C	C	C	C	R - Every one year
9.	Battery electrolyte level		C,A	C,A	C,A	C,A	Every 15 days
10.	Brake light switch		C,A	C,A	C,A	C,A	C,A
11.	Clutch play / Throttle play		C,A	C,A	C,A	C,A	C,A
12.	Rear brake pedal play		C,A	C,A	C,A	C,A	C,A
13.	Brake lining or pads wear (front & rear)		C	C	C	C	Replace if required
14.	Steering play		C,A	C,A	C,A	C,A	C,A
15.	All fasteners tightness including eng. mtg bolt		T	T	T	T	T
16.	Engine mtg. silent bush						C -Every 20,000 kms R-if req.
17.	Tyre thread wear						C -Every 10,000 kms

- : Indicates operation to be performed.
- ★ : More frequent cleaning may be required when driving in dusty condition.

**A - Adjust**  
**CL - Clean**  
**C - Check**  
**L - Lubricate**  
**T - Tighten**  
**R - Replace**  
**D - Drain**

**Note:**  
 Parts / Lubricants to be replaced as per Periodic Maintenance and Lubrication Chart are mandatory and the same are chargeable to customer.

Every 2500 Km. or every 75 days subsequently.

## Periodic Maintenance & Lubrication Chart

**BOXER** *EM 100*

Sr. No.	Operation	Which ever comes first ↓		RECOMMENDED FREQUENCY			
				Initial		Subsequent	
		OR	Kms.	500-750	2,500 kms.		Every 2,500km
	Days	30 - 45	240 days from date of sale		Every 75 days		
18.	General lubrication		L	L	L	L	L
19.	Swing arm pivot pin				L		Every 5,000 kms.
20.	Front fork		C,A		C,A		C,A
21.	Front fork oil						R -Every 10,000 kms.
22.	Fork oil seal and dust seal						R -Every 10,000 kms.
23.	Rear shock absorbers		C	C	C	C	C -Every 2500 kms.
24.	Drive chain adjust						L -Every 500 kms.
25.	Drive chain				C,CL,L		Every 5,000 kms.
26.	Drive chain lock				R		Every 5,000 kms.
27.	Engine compression pressure						C -Every 15,000 kms.
28.	Cylinder block piston & head de-carbonising						Every 15,000 kms.
29.	Valve lapping / Oil seal leakage						C - Every 15000 kms. Every 30,000 kms.
30.	Gap in reed switch & TPS magnet		C	C	C	C	C -Every Service
31.	Silencer drain hole cleaning		CL	CL	CL	CL	CL
32.	Rear sprocket fasteners				T		T -Every 5,000 kms.
33.	Rim run out		C,A	C,A	C,A	C,A	
34.	Front brake lever play		C,A	C,A	C,A	C,A	

- : Indicates operation to be performed.
- ★ : More frequent cleaning may be required when driving in dusty condition.

**A - Adjust**  
**CL - Clean**  
**C - Check**  
**L - Lubricate**  
**T - Tighten**  
**R - Replace**  
**D - Drain**

**Note:**  
 Parts / Lubricants to be replaced as per Periodic Maintenance and Lubrication Chart are mandatory and the same are chargeable to customer.

## Schedule for Periodic Part Replacement

**BOXER** BM 100

Type of service, Kms limits & No of Days →	Days	500~750	4500~5000	9500-10000	14500~15000	19500~20000	24500~25000
		30~45	240	75 Days	75 Days	75 Days	75 Days
Item Description	Qty.						
Clutch Cover Gasket	1	√				√	
Drive Chain Link Lock	1		√	√		√	√
Fork Oil	300 ml			√		√	√
Fork Oil Seal kit	1			√		√	√
Engine Air Breather Tube	1			√		√	√
Air Filter Cover 'O' Ring	1			√		√	√
Rear Wheel Rubber Damper	1			√		√	√
Brake Shoe kit	1				√		
Steering Stem Bearing Cone Set	1				√		√
Spark Plug	1				√		√
Cylinder Head Gasket	1				√		√
Clutch Plate Set	1					√	√
Chain Sprocket kit	1						
Valve Oil Seal kit	1						√
Fr. Br. Accelerator, clutch cable	1						√
Carburettor Duct / Fuel Pipe	1						

Note : Replacement of Parts at periodic interval is mandatory and on chargeable basis.

## Pre Delivery Inspection

**BOXER** BM 100

1. Fill adequate petrol into petrol tank for proper flow of petrol to the carburettor.
2. Check all locks, P.T. cap, ignition switch, steering lock, R.H./L.H. cover. **(As applicable to certain model).**
3. Check for smooth operation for fuel cock.
4. Check engine oil level and top up if required.
5. Check transmission oil level and top up if required. **(As applicable to certain model).**
6. Check all controls for proper free play and function :- Accelerator, clutch lever, front brake lever, rear brake pedal / lever, choke lever. **(As applicable to certain model).**
7. Check gear shifter lever for proper position and working.
8. Inspect rear shock absorber for proper setting and correct if required. **(As applicable to certain model).**
9. Check wheel run out and tighten spokes if required. (As applicable to certain model).
10. Check / Adjust chain slackness appropriately. Lubricate if required. **(As applicable to certain model).**
11. Check brakes and adjust if required.
12. Check and top up brake fluid level. **(As applicable to certain model).**
13. Check and adjust tyre air pressure to the recommended value.
14. Check battery terminal voltage, specific gravity, electrolyte level. Charge the battery if required. Check connection at terminal, starter relay and apply petroleum jelly on terminals if required.
15. Check and adjust steering freeness.
16. Check front mudguard alignment w.r.t. front wheel.
17. Check all important nuts and bolts for proper torque and tightness.
18. Fit all O.E. accessories like mirror, leg guard, muffler guard etc. **(As applicable to certain model).**
19. Start vehicle, check idling and CO%.
20. Check all switches, meters, horn and lights for proper functioning.
21. Test drive the vehicle.
22. Check for oil leakage and rectify if any.
23. Repair for any other defects seen or observed during the test drive before cleaning the vehicle.
24. Clean the vehicle / washing before delivery.

1. Wash the vehicle.
2. Flush & change Engine oil / Top up Oil Level (As per Schedule).
3. Clean air filter. (Replace, As per Schedule).
4. Check and clean fuel line. (Replace filter, if required - If Applicable).
5. Clean oil filter. (Replace, As per Schedule - If Applicable).
6. Clean oil strainer As per Schedule. (Replace, if required - If Applicable).
7. Clean & Drain Carburetor. (Overhaul, if required).
8. Clean, Check & Adjust spark plug gap. (Replace As per Schedule).
9. Check & Correct Wheel Run-out. (If Applicable).
10. Check & Adjust air pressures in the tyres.
11. Check & adjust (if required) valve clearance. (As per Schedule - If Applicable).
12. Adjust chain slackness. Clean & Lubricate Chain, If required (As per Schedule - If Applicable).
13. Check & adjust brakes.
14. Check and top up brake fluid level (If Applicable).
15. Check and adjust steering.
16. Check / Replace Fork Oil, As per Schedule (If Applicable).
17. Check Clutch, Gear, Choke, Accelerator & TPS (If Applicable) and adjust if required.
18. Check & tight Nuts, Bolts & Fasteners to the recommended torque (Refer SSM).
19. Lubricate specific points as per Lubrication Schedule.
20. Check Battery, top up Distilled Water. Route the cables and fit terminal caps properly Clean terminals & apply Petroleum Jelly (If Applicable).
21. Check all Meters for proper functioning.
22. Start vehicle, check & adjust Horn & All Lights for proper functioning.
23. Start vehicle, check idling and CO%. Tune Engine & Carburetor if required.
24. Carry out any additional work if required.
25. Test Ride the Vehicle if required.
26. Clean the vehicle at the time of delivery.